

# Freemelt ONE

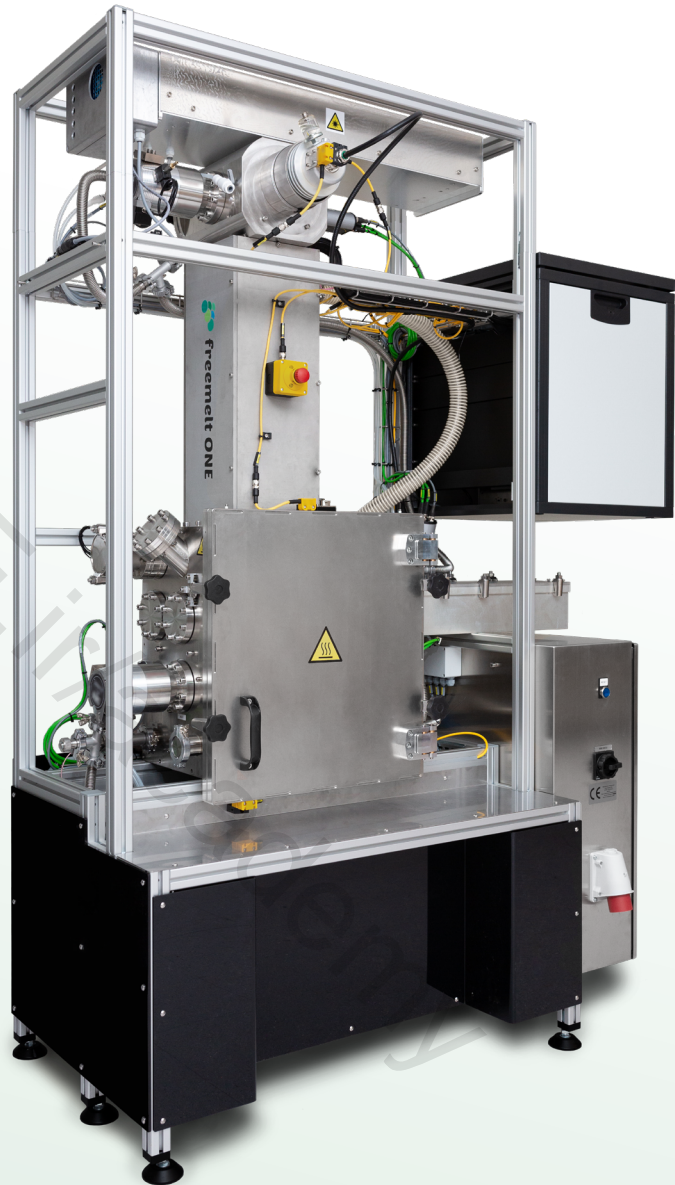

## The 3D printer tailored for materials research and development

Use high beam power melting and fully open beam path sequencing

Create your own IP with total control in the open architecture

Develop new materials optimized for your application

Develop faster processes and use a broader range of metal powders

Take advantage of knowledge and data shared in an open community

Tailor the system to your needs with the open system architecture

## Vacuum chamber

Small vacuum chamber, 70 liters, with high capacity pumps. Tests can be run with very small quantities of powder, thanks to a small build tank and lean powder feeding.

Outstanding vacuum quality due to low outgassing materials, all-metal seals and clever design preventing moisture-absorbing metallization.

Designed for smooth chamber cleaning, with exchangeable panels and easy access. Clean the system and load another material in a couple of hours.

## Electron beam source

The electron beam source is a diode type source with a laser heated cathode. The advantage of this source type is its consistent beam spot quality throughout the entire beam power range 0-6 kW.

Freemelt ONE thus allows you to operate the electron beam at very high beam currents while still maintaining a well-focused beam spot. This is essential to reach high build rates as well as extremely high build temperatures.

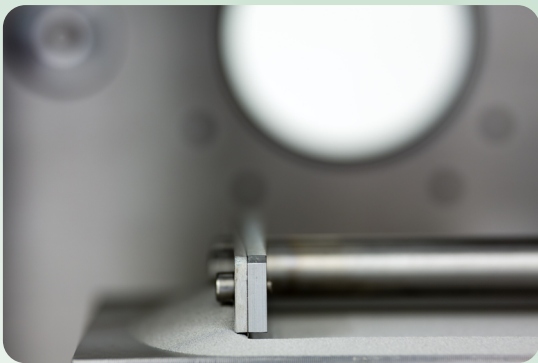
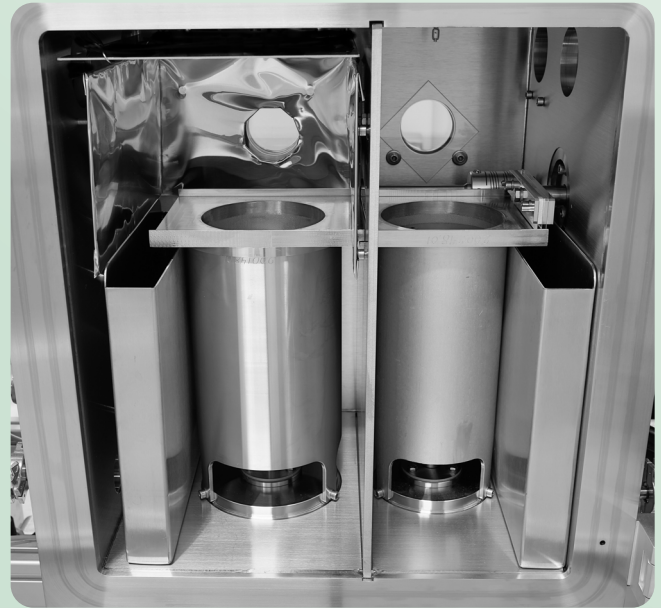

## Powder feeding

The linear motion of the recoater is actuated by a mechanism positioned outside the vacuum chamber. It can easily be accessed and serviced and ensures robustness since it is not exposed to the process conditions.

The design and properties of the recoater blades and the overall design of the recoater can be further modified and optimized by the user. The movement of the recoater and the powder feeding pistons can also be programmed without restrictions.

## Open source

Freemelt is founded based on the idea that metal 3D Printing need to be more open to grow faster in influence and value. Our open source platform lets you use your full potential to develop applications the world has yet to see.

There is more to making a truly open platform than just providing the source code to the user. It should also invite, rather than intimidate, the user. Freemelt is the open source catalyst for the additive manufacturing industry, for software as well as hardware, and we invite everyone to join our openness.

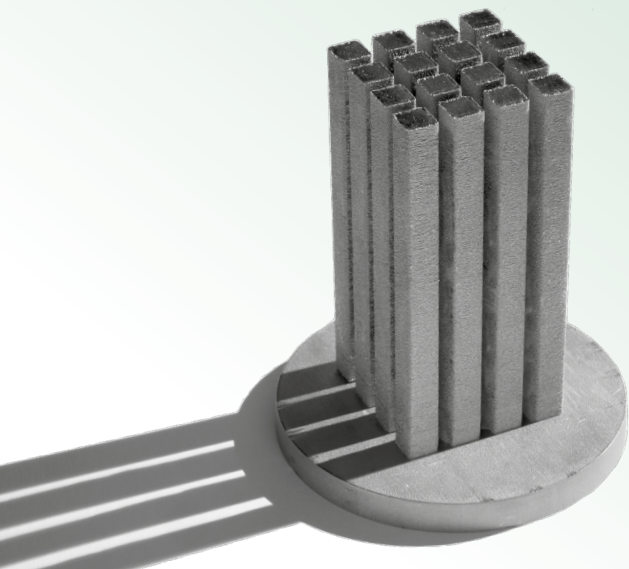

## Backscattered electron detector

The BSE detector collects backscattered electrons from the build area. Electron images can be created similar to a Scanning Electron Microscope. In contrast to a conventional camera, the BSE detector does not need glass viewports, and thus it works well even in presence of metal vapor.

Particularly useful for detecting irregularities, such as porosity or swelling, in each melted powder layer.

### Can be operated in two modes:

COMPO mode, where contrast is created by average atomic number

TOPO mode, where topography provides contrast

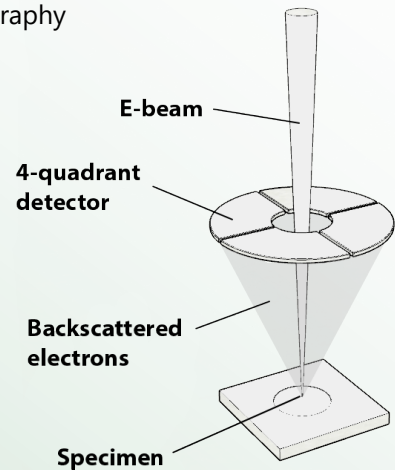
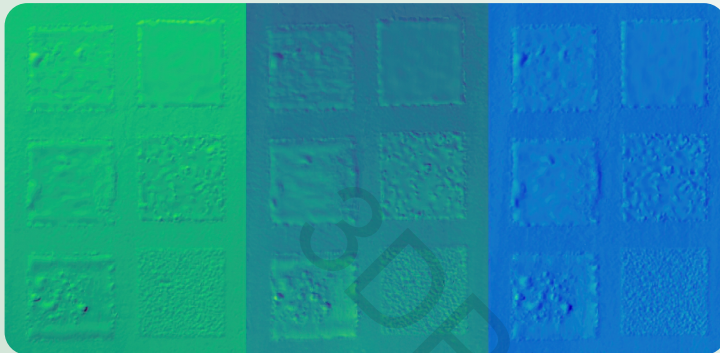

## ProHeat®

ProHeat is a game changer enabling industrially reliable and productive processing with Electron Beam Powder Bed Fusion. ProHeat also opens up a wider range of processable materials. ProHeat is based on heating by electromagnetic radiation from a heating device positioned over the powder bed. The radiation sinters every powder layer smoothly, with zero risk of powder charging and so-called smoke events.

### ProHeat provides a number of benefits over existing E-PBF preheating solutions:

Fast and efficient heating, preserving all unique advantages of a hot and stress-relieved AM process

Preheating without interaction with electrons – eliminating charging of the powder

Highest vacuum purity and optimum beam quality maintained at all times

Uniform sintering of the powder bed results in smoother melting and less spatter

Zero consumption of costly, high-purity inert gas (helium or argon)



## Technical data **Freemelt ONE**

|                                  |                        |
|----------------------------------|------------------------|
| Beam Power:                      | Variable 0-6 kW        |
| Beam acceleration voltage:       | 60 kV                  |
| Build envelope:                  | 100 mm H x 100 mm Ø    |
| Base pressure in vacuum chamber: | $10^{-6}$ hPa (mbar)   |
| Base pressure in electron gun:   | $10^{-7}$ hPa (mbar)   |
| Pumpdown time of vacuum chamber: | <15 minutes            |
| Cathode heater:                  | CO2 Laser              |
| Operating system:                | Linux                  |
| Data clock frequency:            | 350kHz (1MHz optional) |
| Build file format:               | Open Beam Path (OBP)   |



**freemelt**

[www.freemelt.com](http://www.freemelt.com)

[3drevolution@freemelt.com](mailto:3drevolution@freemelt.com)

### **About Freemelt**

Freemelt is a developer and manufacturer of 3D printing technology using electron beam as the energy source.

Freemelt was started by experienced and enthusiastic founders that set out to make a difference in advanced 3D printing. Freemelt evolves but the entrepreneurial attitude of making a difference prevails.

We know that progress is a collective effort that can't be won on your own. Collaboration is key to our mission, with a team and an ecosystem where everyone can participate with their unique skills to contribute to success.

